



11T DEEP RIPPER

Designed for row-crop, cotton and irrigation applications, the C&M 11 Tyne Deep Ripper delivers powerful deep ripping to improve soil structure and planting conditions. Its unique Vee-Design provides excellent fuel efficiency and pulling power for fast, effective operation in demanding conditions.

Built to eliminate hard pans and soil compaction in a single pass, the Deep Ripper also promotes improved moisture movement through the soil.

FEATURES & BENEFITS

- Heavy-duty, fuel-efficient Vee-Design frame
- Hydraulic rotary valve for level control
- 500mm tyne spacing
- 38 inch (965mm) ground clearance
- High strength 32mm 400 grade Bisalloy shanks with 10 tonne breakout force
- Chocolate bar dolomite block on leading edge of tyne
- Hydraulic top-link levelling





**SCAN FOR
MORE INFO**

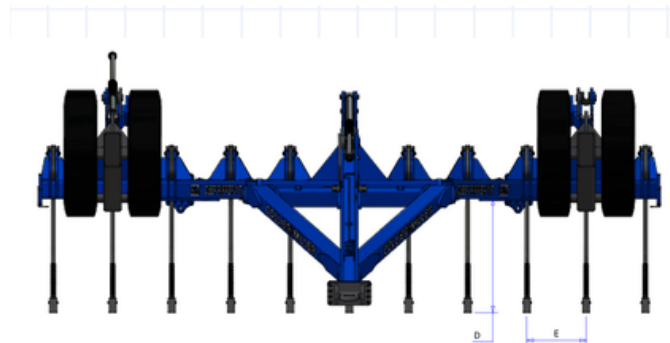
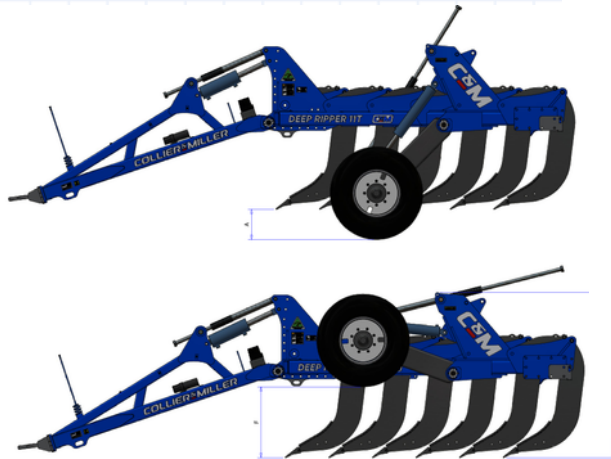
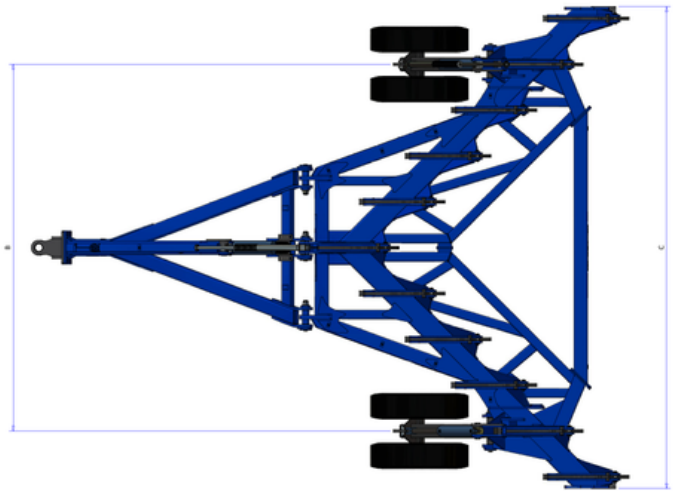

MODEL	CMDR11
DESCRIPTION	11 Tyne Heavy Duty Deep Ripper
TYNE THICKNESS AND MATERIAL	32mm 400 Grade Bisalloy
NUMBER OF TYNES	11
POSITIVE DEEP CONTROL STOPS	Yes
SHEAR PIN BREAK OUT	10,000 kg
AXLES	4500 kg each @ 25kph
TYRES	295/80 R 22.5
A = TRAVELLING CLEARANCE FROM POINT TO GROUND	346mm
B = WHEEL CENTRES	4000mm
C = OVERALL WIDTH OF MACHINE	5244mm
D = CLEARANCE UNDER BAR	964mm
E = TYNE CENTRES	500mm
F = MACHINE RIPPING DEPTH	814mm
G = OVERALL HEIGHT	1895mm
MINIMUM HORSE POWER	400HP
WEIGHT	5900kg
DRAW BAR BUSH DIAMETER	50.8mm
POWDER COATED FINISH	Yes

COLLIER & MILLER